

# The Pink Panther

## Henry J. Kaiser, Jr. Elementary School

25 South Hill Court, Oakland, California 94618 (510) 549-4900

SCHOOL & COMMUNITY NEWSLETTER

MAY 11, 2009

### Our Science Fair begins this Wednesday! Bring in the Projects!

Dear Kaiser Families,

We just passed Mother's day. Like a lot of people I think my mom is pretty special. Like a lot of people I sent her a card and called her. And like a lot of people I remember that no matter what we did she never stopped loving us. That's a huge life lesson. When I'm having difficulty with my boys, I'll call Mom and ask, "What do I do about...?" Often she'll have sage advice that boils down to "make sure they know you love them," even when my kids are acting out!

It's important to remember that constant love when we talk about bullies and their victims. I think one of the hardest things about the issue is that we need to re-frame the situation so that we let go of the notion of "us and them." It's often not so easy to see, especially when our child comes home and says that they didn't do anything, that so-and-so "just hit me!" Many professionals in psychology, spirituality, and education see bullies and victims as two sides of the same coin. Bullies are very often victims themselves. In our lessons about bullying in our classrooms, we teach that there are bullying *relationships* involving bullies, victims and bystanders—and that everyone is getting something out of the relationship.

Bullies are turning their pain and anger on others they see as weaker than they are, so it becomes a power dynamic. Many of us buy into the idea that the bully is the only problem. I think we need to look deeper into why each person involved in such a set up. In the past week I've counseled kids who were arguing in the classroom, teasing others about sex, and fighting on the playground. In all those situations I sensed that the one who caused it was in some way looking for power because they felt weak, and the victim also feels weak and so gives in. In addition to letting the bully know that their behavior is not okay, we must find ways to help both bullies and victims feel confident and competent so they won't need to resort to bullying to satisfy that hunger, or cave in to bullies because they don't feel strong.

So what do we do? The profiles of both the bully and victim come across as people who need more love and support. It is clear that we need to make real in our everyday actions our beliefs that each individual is a valued and precious human being. We do this by recognizing them, being present, listening, and reacting with kindness and respect. Just like our mothers would!

Mel Stenger, principal

## *Getting In The Know*

On behalf of the teachers and staff we want to say "Thanks" to all who made us feel special this week with food, desserts and other recognitions of Teacher Appreciation Week!



Our Orff Music Instructor, Kathy Quain, is looking for some parents to help with visual props for the May 19 performance. Please contact her at [kathyquain@sbcglobal.net](mailto:kathyquain@sbcglobal.net) to be involved.

**Jump Ropes: Please remind your children to never use jump ropes on any climbing structures.**

### **How to be in the *Pink Panther***

To include your story or information in your school newsletter: forward your news, questions, or article to **both** of the editors by **5 p.m. on Sundays** via e-mail:

**[carriemail2001@yahoo.com](mailto:carriemail2001@yahoo.com) – Carrie Shepherd  
[jolie@earthlink.net](mailto:jolie@earthlink.net) – Jolie McRae**

Please put "Pink Panther" in the subject of your email to ensure that it is not deleted accidentally!

### **How to Reach Kaiser School**

Our phone number is **(510) 549-4900**  
(includes a 24-hour message service).

To participate in the school community group,  
go to (and join) this website:  
**[http://groups.yahoo.com/group/  
kaiserelementaryschool\\_group/](http://groups.yahoo.com/group/kaiserelementaryschool_group/)**

### **KAISER CALENDAR**

DATE / DAY	EVENT
May 13-15	Science Fair
May 15	ALIVE Passports Due
May 19	Music Night / Open House for K-3, 6 p.m. -park on the upper playground
May 21	Music Night / Open House for 4-5, 6 p.m. -park on the upper playground
May 22	No School in lieu of Lincoln's Day
May 25	No School Memorial Day
May 27	Volunteer Appreciation Celebration, 1:30 p.m.
May 29	Kaiser ALIVE Picnic 5-7:30am
June 9-11	Minimum Days: 1:25 dismissal

#### **Pink Panther's PTA Sponsors**

PTA President: Janice Murphy

#### **Pink Panther Staff**

Co-editors: Jolie McRae & Carrie Shepherd

Copy editor: Wendy Harcarik

**The Pink Panther is also available at  
[www.KaiserElementary.org](http://www.KaiserElementary.org).**

## Three Cups of Tea Project Update

Here we go! This week the K-3 classes will start to make the dolls. The clothes are ready, the faces, hands, and hair are ready. The Pennies for Peace can is in the hallway—you can start dropping pennies (or change) anytime. Also, parents who would like to help the children assemble can join me in the classroom on Tuesday from 9:30 to 3:00 or on Thursday from 9:00 to 3:00. It will take us two weeks to complete the assembling. Your help means so much to the children and me. Help especially needed with Ms. McGhee's and Ms. Hunter's classes.

What has come to light during this project is that many children, including those in the 4th and 5th grade, have a very hard time cutting. At first I found this very shocking, but upon reflection I suspect that we just don't cut as much anymore. What is tragic is that developmentally this is an important skill for eye-hand coordination and integration of information in the brain. Kummon Reading stresses cut-and-paste activities for acceleration in reading. I am devoted to next year giving some focus on art activities that will increase this skill. At home you can encourage your children to cut for collages or decorations. In our dialogue the children discovered that many occupations require this skill, i.e. surgeons, dentists, architects and astronauts. The other thing they discovered is that cutting with scissors can be very relaxing.

Thank you so very much for your support. Your children are wonderful and I am so blessed.  
—Ms. Leonardo, Art Teacher

Please don't take clothes from the Lost and Found unless it's yours. And please remember to mark your child's clothing!

Our Walkathon was Saturday, May 2. To be considered for prizes you need to turn in your pledges!

## SUMMER PIANO LESSONS!

Where: Kaiser School

When: June 15 - August 12 (1 x week)

Cost: \$20 per lesson + book

Call: Marilyn Marsh (at Kaiser since 1994)

Phone: (510) 923-1620

## Calendar of upcoming events:

**May 19:** K-3 Open House and Music night, 6 p.m. Park on the upper playground.

**May 21:** grades 4-5 Open House and Music night, 6 p.m. Park on the upper playground.

**May 27:** Volunteer celebration, 1:30 p.m. We want to thank everyone who has volunteered in our school this year. Because we can't possibly remember every person by name, please let Robin know by May 13 if can join us for the celebration.

## Kaiser ALIVE's Final Week

Another year of the Kaiser ALIVE! Program is coming to an end. Your booklets are due back to your teachers by **Friday, May 15th**. Please take advantage of this last week to complete your personal activity goals.

<b>Points</b>	<b>Raffle Prize</b>
100 - 149	Webkinz of your choice
150 - 199	1 yr to National Geo Mag or \$20 Gift Card
200 - 249	6 month to Club Penguin or \$30 Gift Card
250 - 299	iPod Shuffle (2nd Gen)
300+	iPod Nano

We hope that a fun time was had by all and look forward to seeing you at the Kaiser ALIVE! Celebration Picnic at Lake Temescal Park on Friday May 29<sup>th</sup> (details below). Come to play, socialize, and eat. You can either share in the fabulous Taco Dinner (\$6 per person) or bring your own picnic. Remember to bring blankets and/or chairs for seating.

Location: Lake Temescal Park (Broadway side of the park)  
 Date: Friday May 29, 2009  
 Time: 5 PM - 7:30 PM

### Schedule of Events:

5:00 PM Party begins  
 6:00 PM Taco Dinner is served (Note: orders due to the school office by May 15<sup>th</sup>)  
 6:45 PM Awards Ceremony and Raffle  
 7:15 PM Clean Up

**Thank you for your participation and we look forward to seeing you on May 29th!**

## How Far Have You Gone????

Color in each box once you have completed the points

5	10	15	20	25	30	35	40	45	50	Prizes
55	60	65	70	75	80	85	90	95	100	<b>Prize Level 1 - Webkinz</b>
105	110	115	120	125	130	135	140	145	150	<b>Prize Level 2 - Nat'l Geo Magazine or \$20 Gift Card*</b>
155	160	165	170	175	180	185	190	195	200	<b>Prize Level 3 - 6 Months to Club Penguin or a \$30 gift card*</b>
205	210	215	220	225	230	235	240	245	250	<b>Prize Level 4 - iPod shuffle 2nd Gen*</b>
255	260	265	270	275	280	285	290	295	300	<b>Prize Level 5 - iPod Nano*</b>

**\*Gift cards from Game Stop, Sport Authority or Target**

## Kaiser Elementary School Wellness Council

### Helping to Raise Healthy Children



Summer is coming. Many of us will be spending more time outside. We are lucky to live in the Bay area where there are miles and miles of places to ride bikes. Before you start—please take the following bike safety quizzes.

#### Be a Safe Bike Rider!

##### True or False?

- \_\_\_ I should ride my bike on the sidewalk until a grown-up I live with says I can ride on the street.
- \_\_\_ I should stop before crossing the street and look LEFT-RIGHT-LEFT for cars.
- \_\_\_ Watch out for cars coming out of driveways and stop if there is a car.
- \_\_\_ When I do ride on the street, I should ride on the right side—the same as cars.
- \_\_\_ I should wear my helmet when I ride my bike.
- \_\_\_ I should have fun riding my bike.

Here are the answers — They are all TRUE!!

#### Here's Another Quiz

Do the "Eyes, Ears, Mouth Test" to make sure your helmet fits. (Fill in the blanks.)

You should see the front of your helmet when you look up past your \_\_\_\_brows.

The straps should meet right under your \_\_\_\_\_ to make a Y.

The straps should be tight enough that you can feel the helmet pull down if you open your \_\_\_\_\_, but loose enough that you can breathe!

ANSWERS: EYES, EARS, MOUTH!!

If your helmet doesn't fit right, have a grown-up you know help you fix it.

For more information, go to "Safety Education" at [www.bikelib.org](http://www.bikelib.org)

Thanks to the *Bicycle Coalition of Maine*.

Some ideas on where to ride from the Berkeley Parents Network:

Inspiration Point in Tilden Park has a nice paved trail. Often used by families w/ stroller, tricycles, bikes, rollerblades etc... A bit of a drive to get there but the best view of anywhere

You can ride all the way around Cesar Chavez Park at the Berkeley Marina. Remember that it can be quite windy out on the bay.

There is a flat, paved bike path along the waterfront from Emeryville to Richmond.

### Some additional tips:

Make sure your brakes are working.

Make sure your tires have the correct amount of air in them.

Take your water bottle and make sure you drink frequently.

Rest if you get tired.

Pack some healthy snacks for your ride.

### Snack ideas:

Peanut butter and apple slices

String cheese

Carrot and celery sticks

Fruit bars

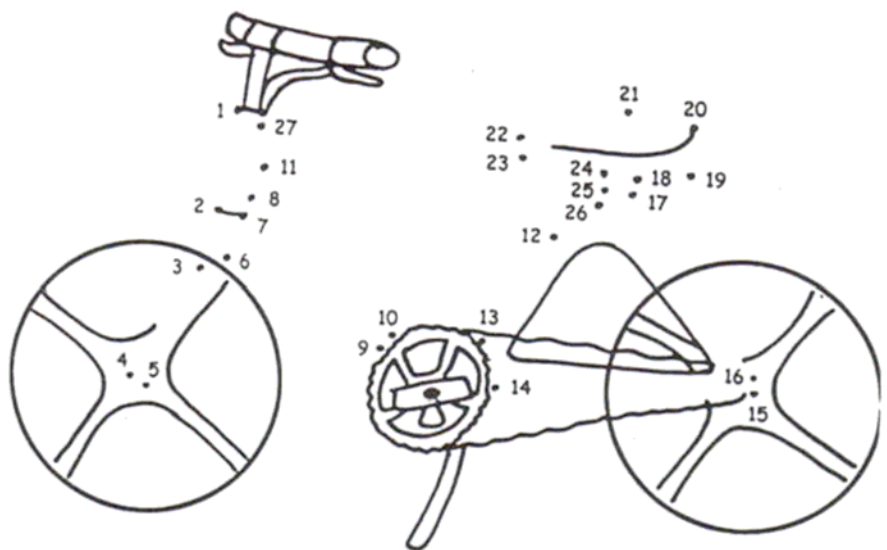

# **AUCTION 2009-2010 PLANNING MEETING**

**Dear Kaiser Community,**

**Our school's biggest fundraising event is the Fall Auction. Preparation and planning requires many minds, hands and good spirits. We will need support in many areas and are also looking for a couple of people to take the lead with check-out and donation solicitations.**

**Come share your talents! Our first committee meeting will be this coming Friday, May 15 at 7:00. If interested, please RSVP to [lavalos@sbcglobal.net](mailto:lavalos@sbcglobal.net). We encourage Kindergarten and 1<sup>st</sup> Grade parents to join so that the torch can be passed on.**

**See you then,**

**Dora Pulido-Tobiassen and Letty Avalos  
2009-2010 Auction Co-Chairs**